



# muswellbrook shire council

## Footpaths and Kerb and Guttering

Policy No. F10/1

**Assembled by  
Neil Pope**

**Adopted By Council  
28 March, 2011  
Minute No. 479**

# **Footpaths and Kerb and Guttering**

**F10/1**

## **POLICY OBJECTIVES**

### **1. Contribution from Property Owners**

Refer to Policy K10/1 – Kerb and Gutter and Footpath Contributions Policy

### **2. Footpath Maintenance**

#### **i) Extent of Footpath Maintenance by Council**

Council's resources are such that the routine maintenance of footpaths cannot be carried out as a normal practice.

Therefore, Council does not carry out grass cutting or other maintenance as a normal practice.

Maintenance and repair of the driveway access to properties is also the responsibility of the resident.

#### **ii) Maintenance and Restoration Works by Council**

Council carries out maintenance on the kerb and gutter, tree lopping (refer to Policy S29\1 and repairs to footpaving construction.

Any restoration work carried out on the footpath as a result of construction works shall be to a standard equal to or better than that which existed previously.

### **3. Services**

Allocation of space for services within the road reservation is shown in Drawing No. 3. All utility services shall be placed in their respective allocated spaces unless otherwise approved by the Transport and Drainage Co-Ordinator or the Manager of Community Infrastructure.

Any services which require relocating for a resident shall be approved by the Manager of Community Infrastructure and paid for by the resident.

### **4. Stormwater Drainage**

All drainage lines shall enter the kerb and gutter with an approved 120X55 rectangular converter. Kerb and gutter shall be broken neatly between two saw cuts and restored to match the existing standard of adjacent kerb and gutter. Drainage lines across footpaths shall be equivalent to Class SH sewer pipe.

### **5. Access**

The construction of driveway accesses will be at the landowners cost.

- a) Standard Access  
Where a driveway is to enter existing kerb and gutter, it shall be broken out neatly between two saw cuts. The layback shall be constructed in accordance with details on Drawing No. 4. Any driveway made redundant shall be broken out and replaced with standard kerb and gutter.

Access for residential driveways shall be brick paved, bitumen sealed, approved ornamental gravel or concrete, in accordance with Drawing numbers 1 and 2 respectively.

- b) Non Standard Driveways
- i) Where access is difficult because of the terrain, approval by the Manager of Community Infrastructure for a non standard driveway will be required.
- ii) In some older parts of the towns where access is difficult by virtue of excessive road crossfalls and high kerb and gutter, gutter bridges may be constructed with the approval of the Manager of Community Infrastructure. Each gutter bridge shall be constructed in accordance with Drawing No. 5.

## 6. Footpath Standards

- i) Allocation of Space
- Footpaths shall be constructed on an alignment shown in Diagram 3 unless otherwise approved by the Manager, Community Infrastructure.

- ii) Design Standards
- The geometric design for footpaths and cyclepaths shall be in accordance with Ausspec Design Specification D9.

### *Concrete Footpaths/Cyclepaths*

Standard concrete footpaths and cycleways shall be a minimum of 100mm thick, reinforced with SL62 mesh and otherwise generally in accordance with Cement and Concrete Association Guide to Residential Streets and Paths

Footpaths and cyclepaths across driveways shall be strengthened for the full width of the drive generally in accordance with Cement and Concrete Association Guide to Residential Streets and Paths.

Concrete shall be finished with a light broom finish.

- iii) Construction Standards
- Concrete or brick paving shall be constructed in accordance with Ausspec Construction Specification.

\*\*\*\*\*

**Author**

**Date**

**REVIEW HISTORY:**

	<i>Current</i>	<i>Previous</i>	<i>Prior</i>	<i>Prior</i>
<i>Minute No:</i>	12	1001	919	137
<i>Meeting Date:</i>	12/07/2004	14/04/2003	14/08/2000	6/4/1998
<i>Review Date:</i>				
<i>Rescind Date:</i>				

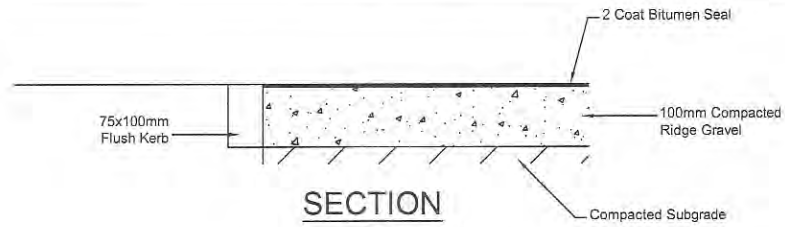

**SECTION**  
**BITUMEN SEALED**  
**STANDARD VEHICULAR DRIVEWAY**

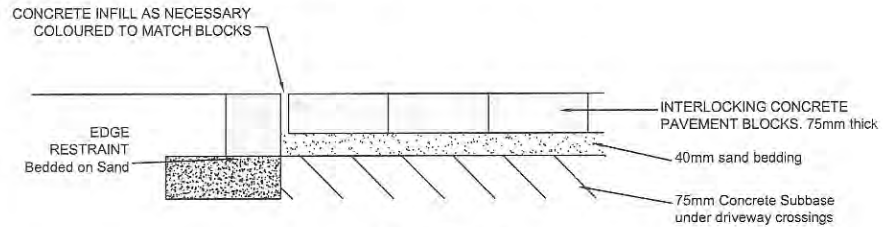

**SECTION**  
**INTERLOCKING PAVEMENT FOR**  
**STANDARD VEHICULAR DRIVEWAY**

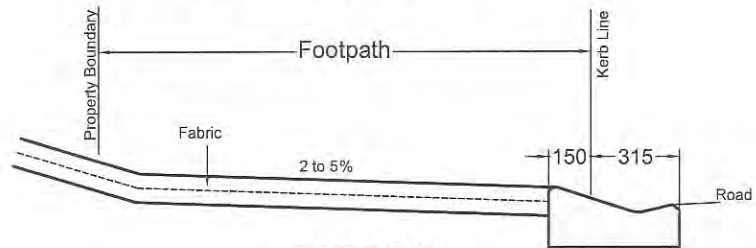

**SECTION**  
**CONCRETE VEHICULAR DRIVEWAY**  
**STANDARD**

1. Full apron type driveways shall be constructed from driveway layback to property boundary.
2. Driveway profiles must lie within the approved envelope. (Refer Fig.15 Revn.A)
3. A driveway design should be completed as a prerequisite for determining house/garage position and floor levels, and before any driveway work is undertaken.
4. The cross slope of the driveway crossing over the footway within 3m. of the kerb line is to be the same as the slope of the abutting kerb and gutter.
5. **Construction Standards:** Concrete paving to be a min. of 125mm thick 25MPa concrete reinforced with one layer of SL62 fabric placed in the upper half of the concrete (min. cover 40mm).  
 "Heavy Duty" crossings to be a min. of 175mm thick 25MPa concrete reinforced with one layer of SL82 fabric placed in the upper half of the concrete (min. cover 40mm).

REVISION	S.D. No. 1	MUSWELLBROOK SHIRE COUNCIL
		SUBDIVISION CODE
	June 2004	VERICULAR DRIVEWAY STANDARD

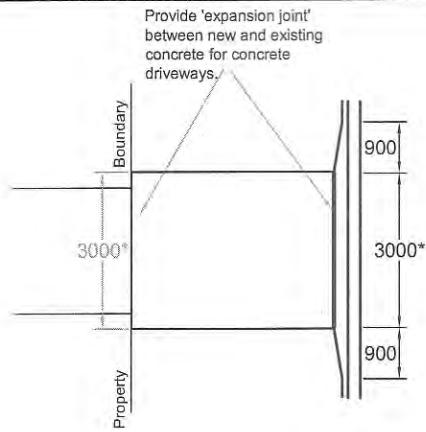

\*Minimum dimension for residential driveways

### DRIVEWAY PLAN

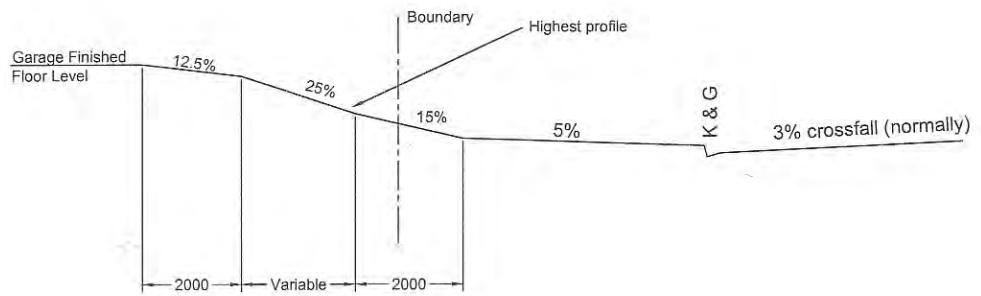
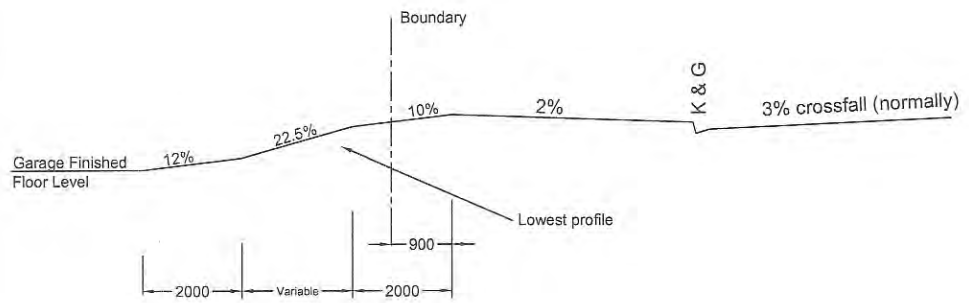

### PERMITTED DRIVEWAY PROFILES

Note  
Driveways to be in accordance with AS 28901.1 2004.

REVISION	S.D. No.2	MUSWELLBROOK SHIRE COUNCIL
		SUBDIVISION CODE
	June 2004	VERICULAR DRIVEWAY STANDARD

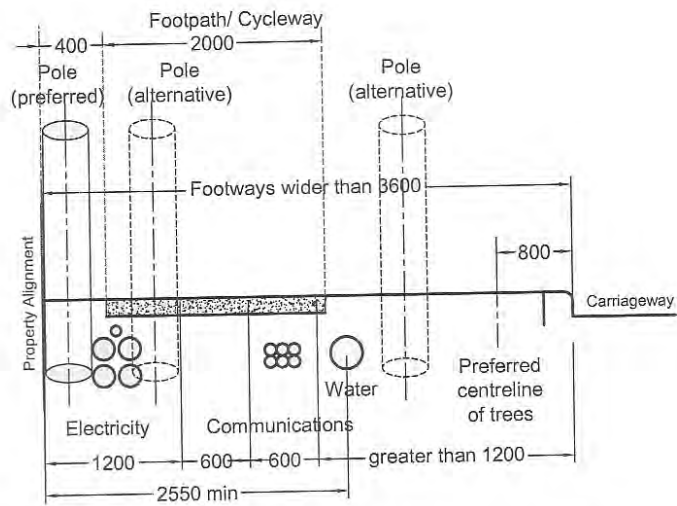

Location of services should be in accordance with the New South Wales Streets Opening Conference Codes and Practices

**Reference:**

New South Wales Streets Opening Conference Codes & Practices

S.D. No.3	MUSWELLBROOK SHIRE COUNCIL
	SUBDIVISION CODE
June 2004	<b>PUBLIC UTILITY MAINS ALLOCATION</b>

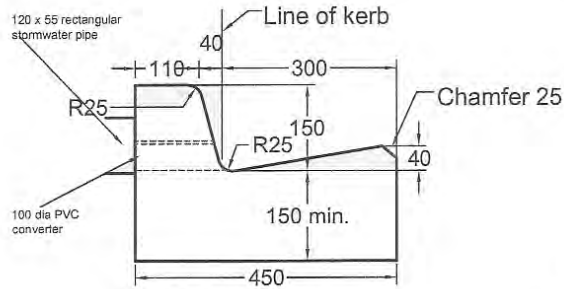

**STANDARD KERB & CHANNEL**  
'X' SECTION AREA 0.094m<sup>2</sup>

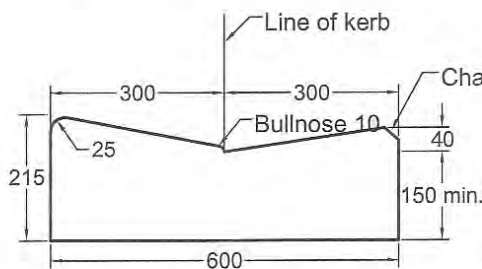

**MOUNTABLE KERB & CHANNEL**  
'X' SECTION AREA 0.159m<sup>2</sup>

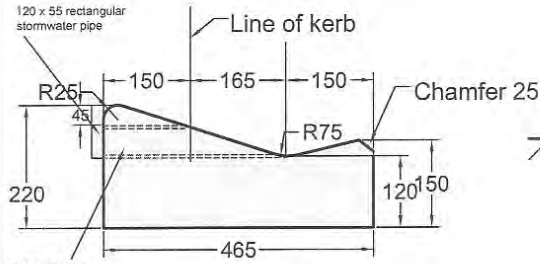

**LAYBACK KERB & CHANNEL**  
'X' SECTION AREA 0.165m<sup>2</sup>

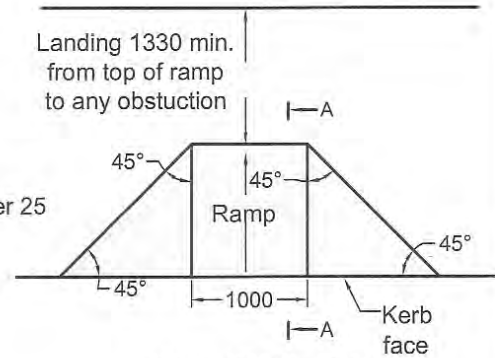

**PRAM RAMP - PLAN**

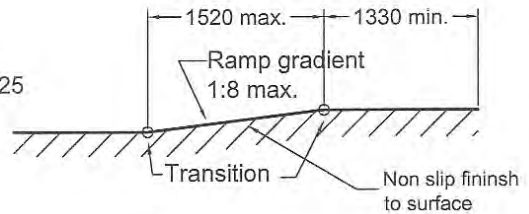

**PRAM RAMP - Section A-A**

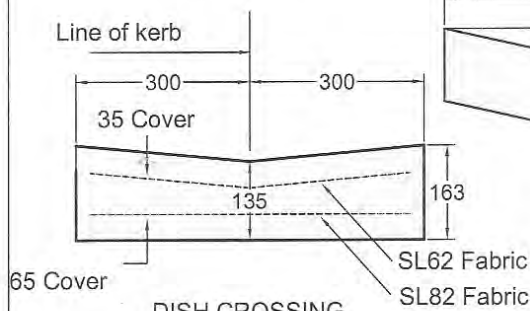

**DISH CROSSING**  
'X' SECTION AREA 0.153m<sup>2</sup>

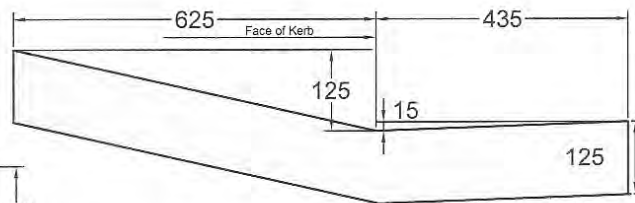

**LAYBACK FOR VEHICULAR ENTRANCE**

'X' Section area 0.131m<sup>2</sup>

Reference:  
AS 2876 (1987)  
AS 1428.1 (1998)

J:\Assets - Roads\A All Roads\Kerb & Gutter Standards.dwg

S.D. No.4	MUSWELLBROOK SHIRE COUNCIL
	SUBDIVISION CODE
June 2004	<b>KERB AND GUTTER STANDARDS</b>

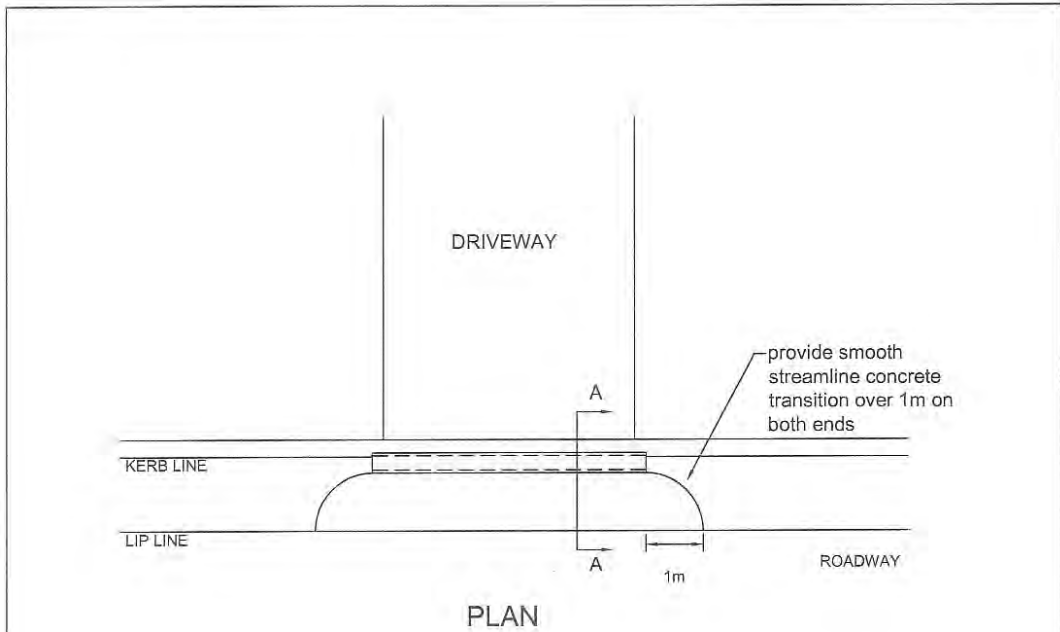

PLAN

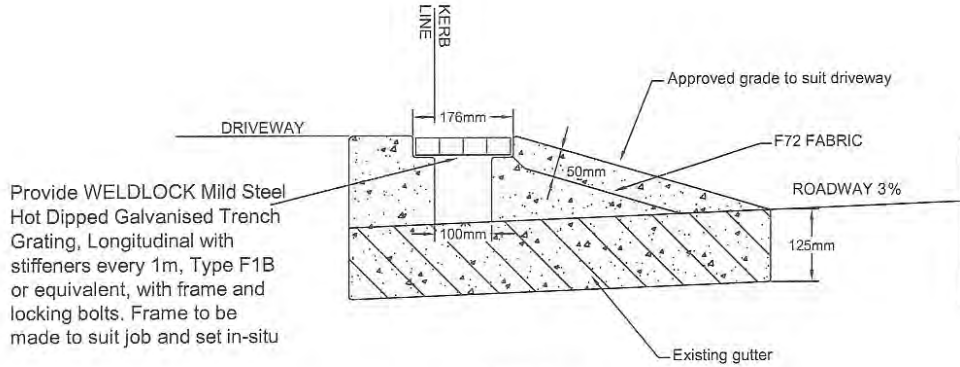

SECTION A - A

NOTES

1. Existing kerb or layback to be broken out between to neat saw cuts and concrete to be poured in-situ
2. Minimum concrete strength to be 20 MPa, with F72 Fabric placed 50mm from top.
3. Prior to concreting, 24 hrs notice is to be given to Council's Engineering Dept.

S.D. No.5	MUSWELLBROOK SHIRE COUNCIL
	SUBDIVISION CODE
June 2004	STANDARD GUTTER BRIDGE